

Activation Solutions Catalogue

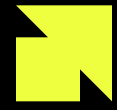



Introduction

This catalogue presents a curated selection of interactive activation solutions designed for fast deployment and proven engagement.

Each experience is built to be intuitive, modular, and adaptable, enabling brands to create impactful moments across a wide range of environments.

With over 30+ solutions, the system is designed to scale from quick installations to fully customized brand experiences.

Table of Contents

Catalogue	3
Touchscreen Games	4
Analogue Retro Games	9
Phygital Games	17
DIY Station	24
Activation Utility	28

Brand Customization	34
---------------------	----

About Descifer	37
----------------	----

Contacts	40
----------	----



Activation Catalogue

Modular solutions.
Built for engagement.

Touchscreen Games

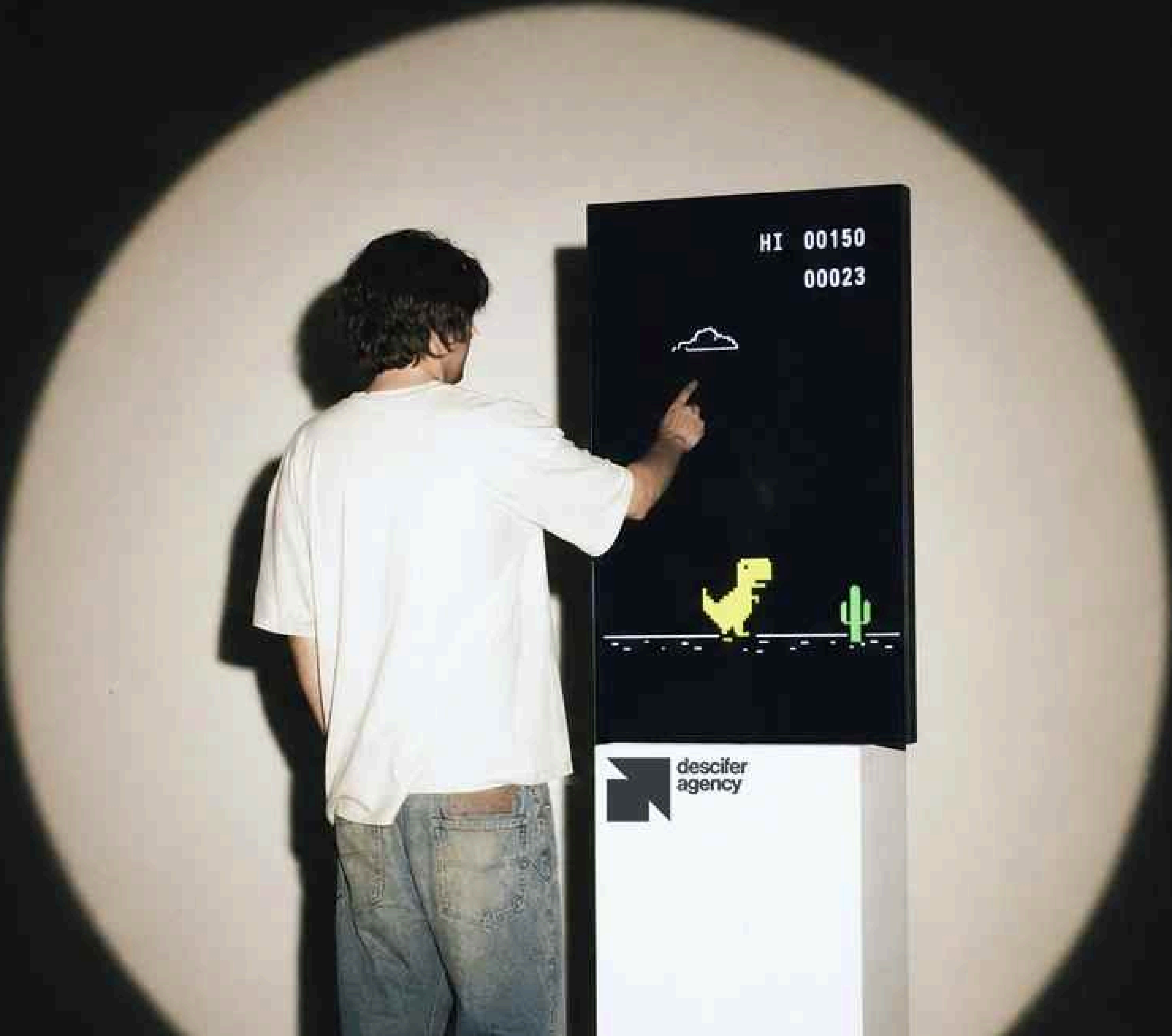

Overview

A plug-and-play collection of hypercasual games designed for fast engagement and high participation. Built for touchscreens of any size or orientation, these games are optimized for quick play cycles, allowing users to jump in, play, and move on seamlessly.

Flexible Integration
Can operate as a standalone unit or be embedded within larger activation builds.

On-Ground Facilitation
Optional trained staff to guide gameplay and enhance user experience.

Engagement Tracking
QR-based web app with OTP login to track participation, capture data, and manage prize distribution.

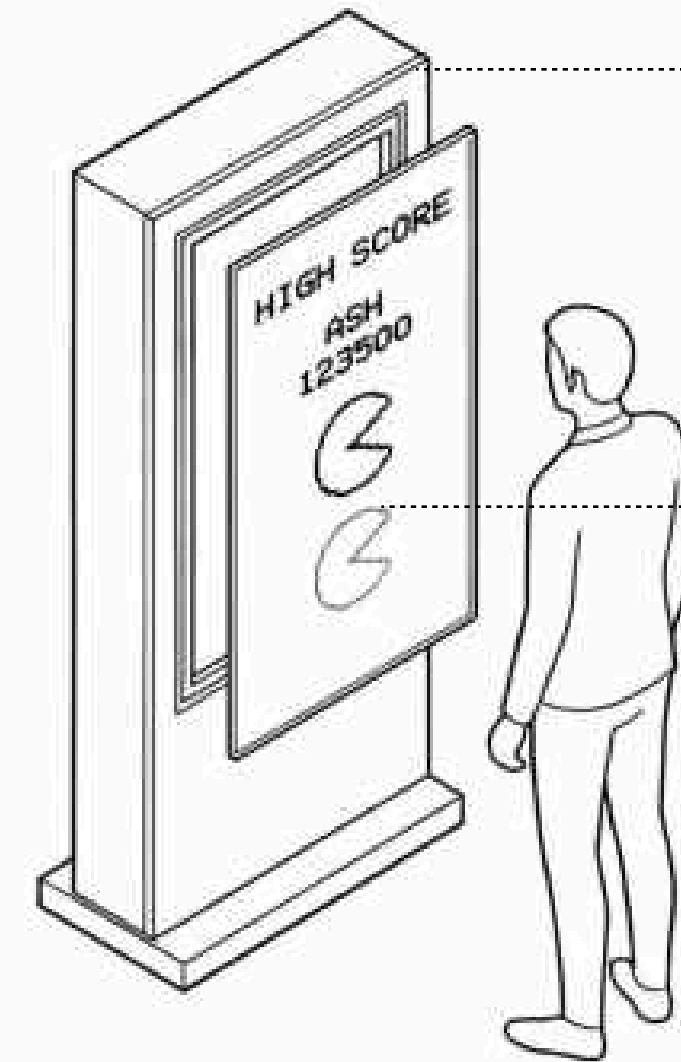
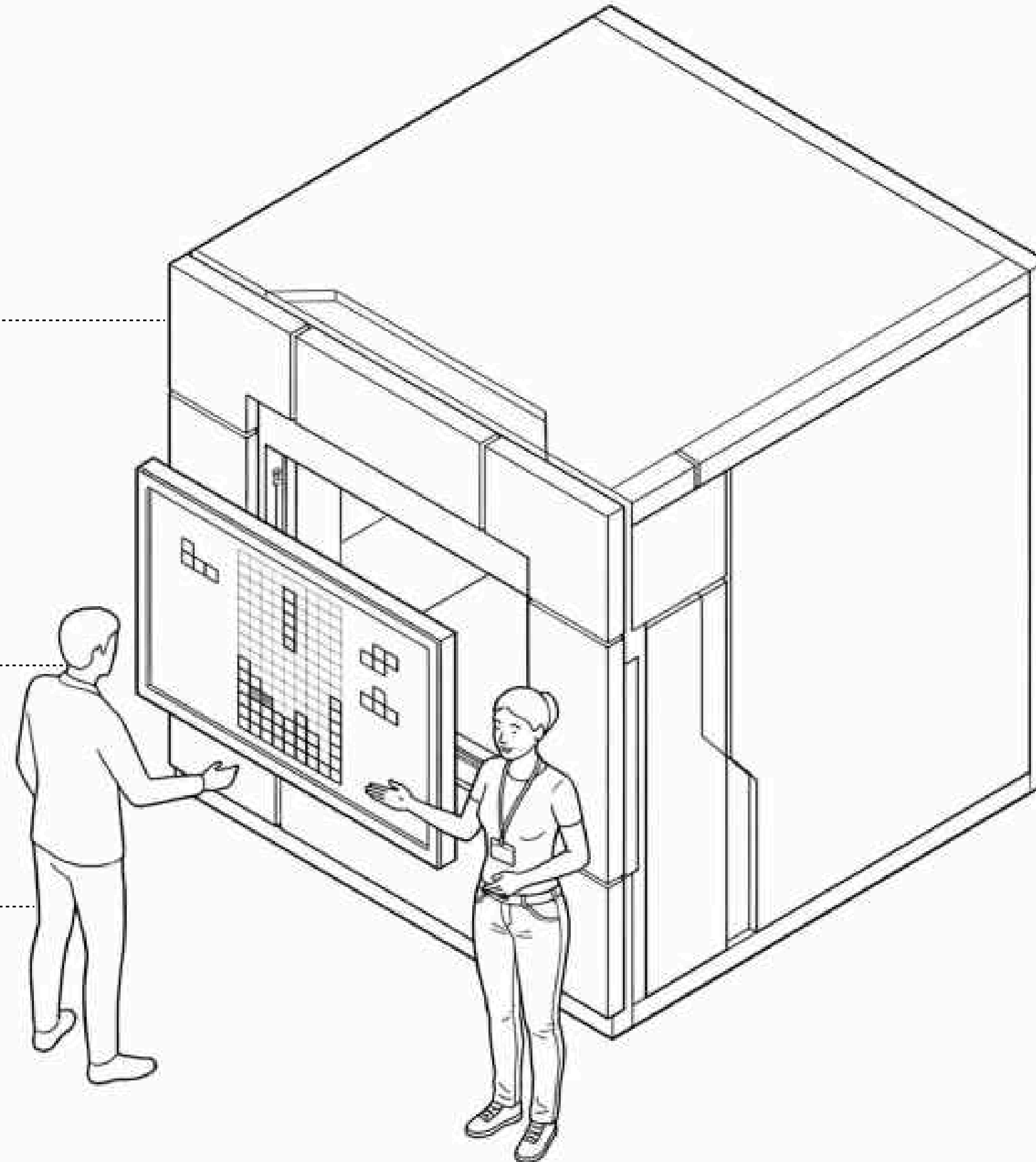

Branded Screen Casing
Available in foamboard or wood, fully wrapped in branded vinyl finishes.

Branded Game Software
Adapt visuals to your brand with custom logos, colors, fonts, and UI elements.

Flip & Match

Timed card-matching challenge where players flip tiles to find identical pairs before the timer runs out. Difficulty scales with grid size and time pressure.

SKU ID	TG-001
Category	Touch Screen Games: Skill Challenge
Interaction duration	30-60 seconds
Daily interactions	200-400 participants per day
Lead time	4-5 working days (Qatar)
Base package	55" touchscreen display Custom-branded game software Custom-branded screen casing
Upgrades	Game usher with custom tshirt Gameplay modifications Data analytics integration

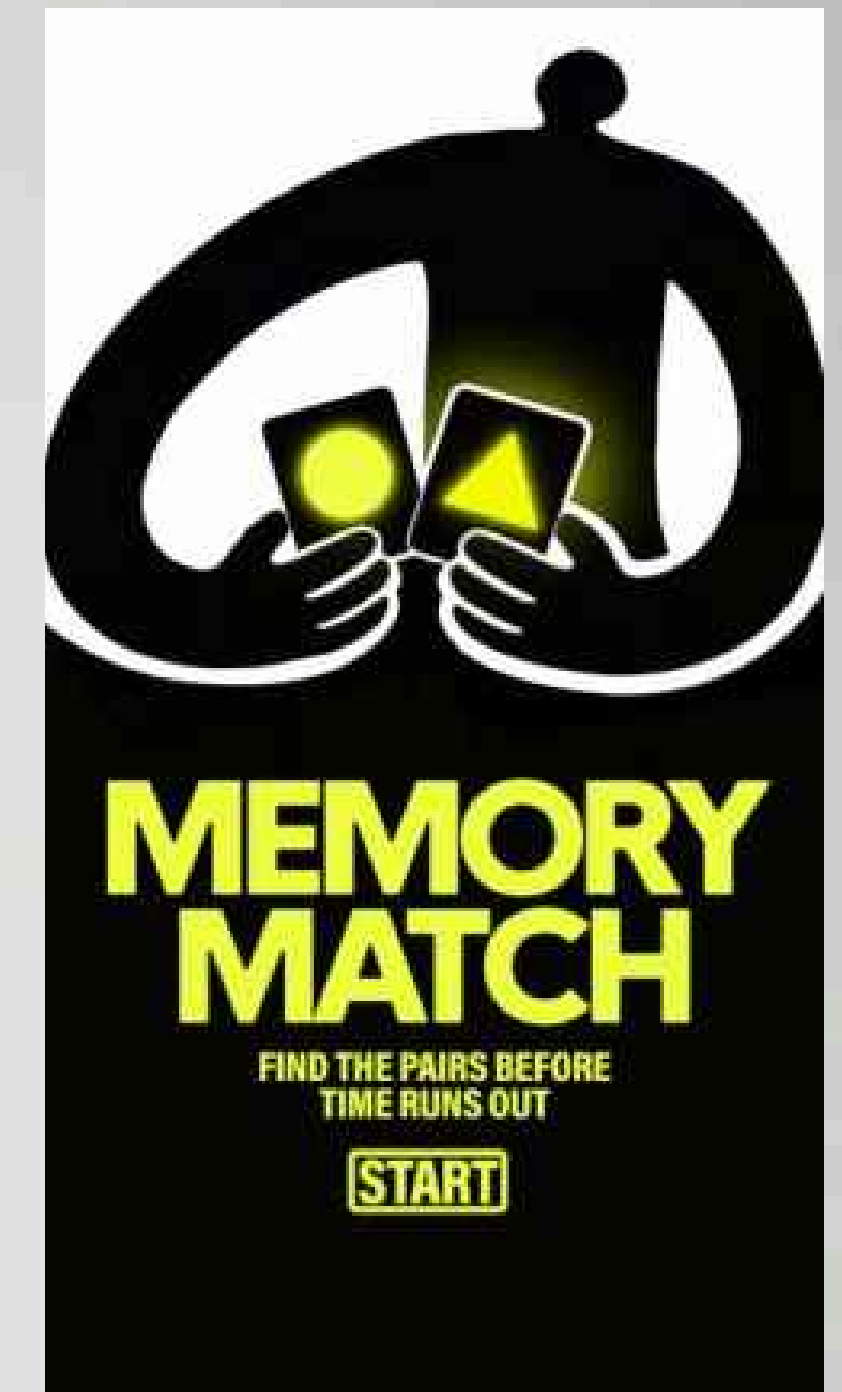

Color Sequence

Players memorize and repeat an increasingly complex sequence of colors or lights. Each correct round increases the difficulty and speed.

SKU ID	TG-002
Category	Touch Screen Games: Skill Challenge
Interaction duration	30-60 seconds
Daily interactions	200-400 participants per day
Lead time	4-5 working days (Qatar)
Base package	55" touchscreen display Custom-branded game software Custom-branded screen casing
Upgrades	Game usher with custom tshirt Gameplay modifications Data analytics integration



Perfect Timing

A reflex timing game where players must tap the screen at the exact moment a moving indicator reaches the target zone. Precision determines the score.

SKU ID	TG-003
Category	Touch Screen Games: Skill Challenge
Interaction duration	30-60 seconds
Daily interactions	200-400 participants per day
Lead time	4-5 working days (Qatar)
Base package	55" touchscreen display Custom-branded game software Custom-branded screen casing
Upgrades	Game usher with custom tshirt Gameplay modifications Data analytics integration



One Tap Runner

A fast-paced endless runner game where players tap once to jump obstacles and survive as long as possible while the speed gradually increases.

SKU ID	TG-004
Category	Touch Screen Games: Skill Challenge
Interaction duration	30-60 seconds
Daily interactions	200-400 participants per day
Lead time	4-5 working days (Qatar)
Base package	55" touchscreen display Custom-branded game software Custom-branded screen casing
Upgrades	Game usher with custom tshirt Gameplay modifications Data analytics integration



Tile Puzzle

Rearrange scrambled tiles by sliding them into empty spaces to reconstruct the correct image before the timer expires.

SKU ID	TG-005
Category	Touch Screen Games: Skill Challenge
Interaction duration	30-60 seconds
Daily interactions	200-400 participants per day
Lead time	4-5 working days (Qatar)
Base package	55" touchscreen display Custom-branded game software Custom-branded screen casing
Upgrades	Game usher with custom tshirt Gameplay modifications Data analytics integration



Spot the Difference

Players compare two nearly identical images and tap the visual differences within a limited time window.

SKU ID	TG-006
Category	Touch Screen Games: Skill Challenge
Interaction duration	30-60 seconds
Daily interactions	200-400 participants per day
Lead time	4-5 working days (Qatar)
Base package	55" touchscreen display Custom-branded game software Custom-branded screen casing
Upgrades	Game usher with custom tshirt Gameplay modifications Data analytics integration



Swipe Catch

Players swipe quickly across the screen to catch falling or moving objects while avoiding obstacles. Speed and accuracy determine the final score.

SKU ID	TG-007
Category	Touch Screen Games: Skill Challenge
Interaction duration	30-60 seconds
Daily interactions	200-400 participants per day
Lead time	4-5 working days (Qatar)
Base package	55" touchscreen display Custom-branded game software Custom-branded screen casing
Upgrades	Game usher with custom tshirt Gameplay modifications Data analytics integration

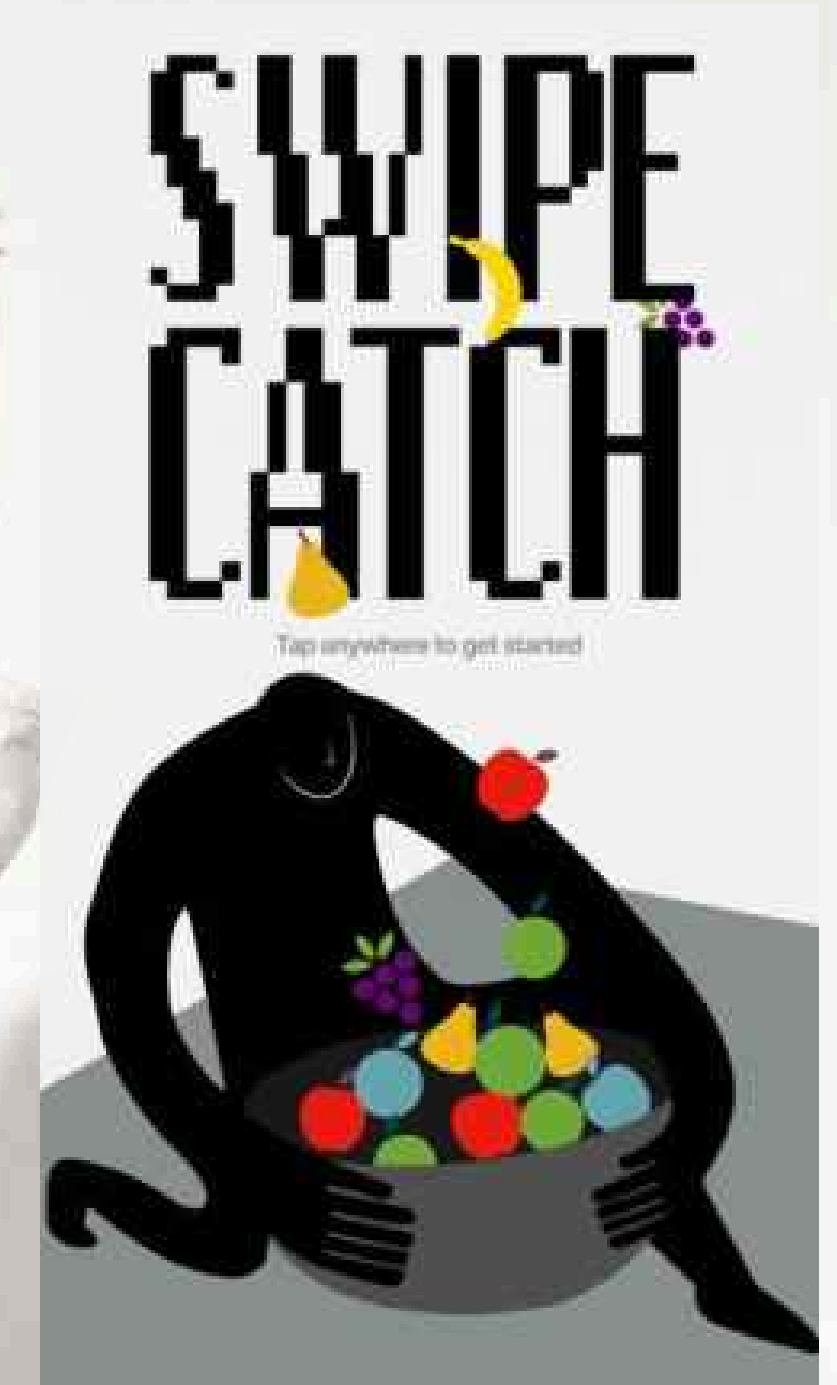

Stack

A timing-based stacking challenge where players stop moving blocks at the perfect moment to build the tallest possible tower.

SKU ID	TG-008
Category	Touch Screen Games: Skill Challenge
Interaction duration	30-60 seconds
Daily interactions	200-400 participants per day
Lead time	4-5 working days (Qatar)
Base package	55" touchscreen display Custom-branded game software Custom-branded screen casing
Upgrades	Game usher with custom tshirt Gameplay modifications Data analytics integration



➤ Analog Retro Games



Overview

A collection of modular, pre-fabricated machines inspired by classic arcade experiences. Designed to bring back the charm of retro games, these installations combine tactile interaction with high-visibility engagement, making them ideal for prize-driven activations and nostalgic brand moments.

Modular Game Structures

Pre-built units designed to adapt seamlessly to different activation environments.

On-Ground Facilitation

Trained staff manages gameplay, guide participants, and maintain flow.

Custom Branding Options

Finished with paint or vinyl wraps to match your brand identity and visual language.

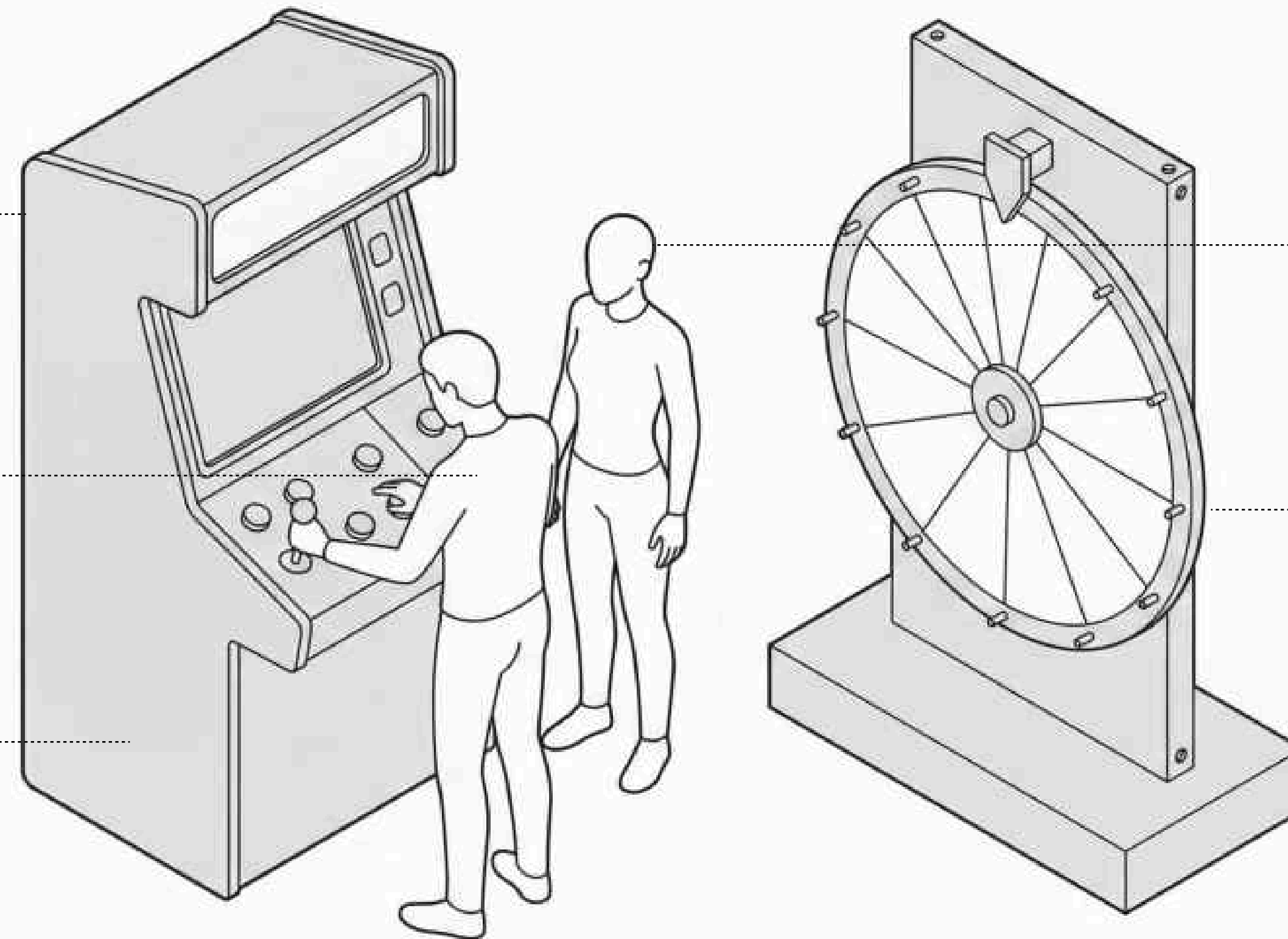

Data & Engagement Tracking

Capture participation data and integrate tracking mechanisms for campaigns and prize distribution.

Retro-Inspired Appeal

Designed to evoke familiar arcade experiences with a modern, brand-ready execution.

Prize Wheel Classic

Participants spin a large prize wheel to randomly determine rewards, outcomes, or promotional offers.

SKU ID	AR-005
Category	Analog Retro: Chance Mechanic
Interaction duration	15-25 seconds
Daily interactions	400-500 participants per day
Lead time	4-5 working days (Qatar)
Base package	Custom-branded spin-wheel
Upgrades	Game usher with custom tshirt Data analytics integration



Wind Chamber

Players attempt to catch floating foam balls to capture prizes from a transparent chamber.

SKU ID	AR-009
Category	Analog Retro: Skill Challenge
Interaction duration	15-25 seconds
Daily interactions	400-500 participants per day
Lead time	4-5 working days (Qatar)
Base package	Custom-branded wind chamber Color foam balls (3 colors)
Upgrades	Branded vouchers (3-designs) Booth facilitator with custom tshirt Data analytics integration



Prize Wheel Barrel

Participants spin a large prize wheel to randomly determine rewards, outcomes, or promotional offers.

SKU ID	AR-010
Category	Analog Retro: Chance Mechanic
Interaction duration	15-25 seconds
Daily interactions	400-500 participants per day
Lead time	4-5 working days (Qatar)
Base package	Custom-branded wheel barrel
Upgrades	Game usher with custom tshirt Data analytics integration



Stop the Clock

An analog challenge where players try to stop the clock at exactly 10 seconds.

SKU ID	AR-011
Category	Analog Retro: Skill Challenge
Interaction duration	15-25 seconds
Daily interactions	400-500 participants per day
Lead time	4-5 working days (Qatar)
Base package	Custom-branded game popup
Upgrades	Game usher with custom tshirt Data analytics integration

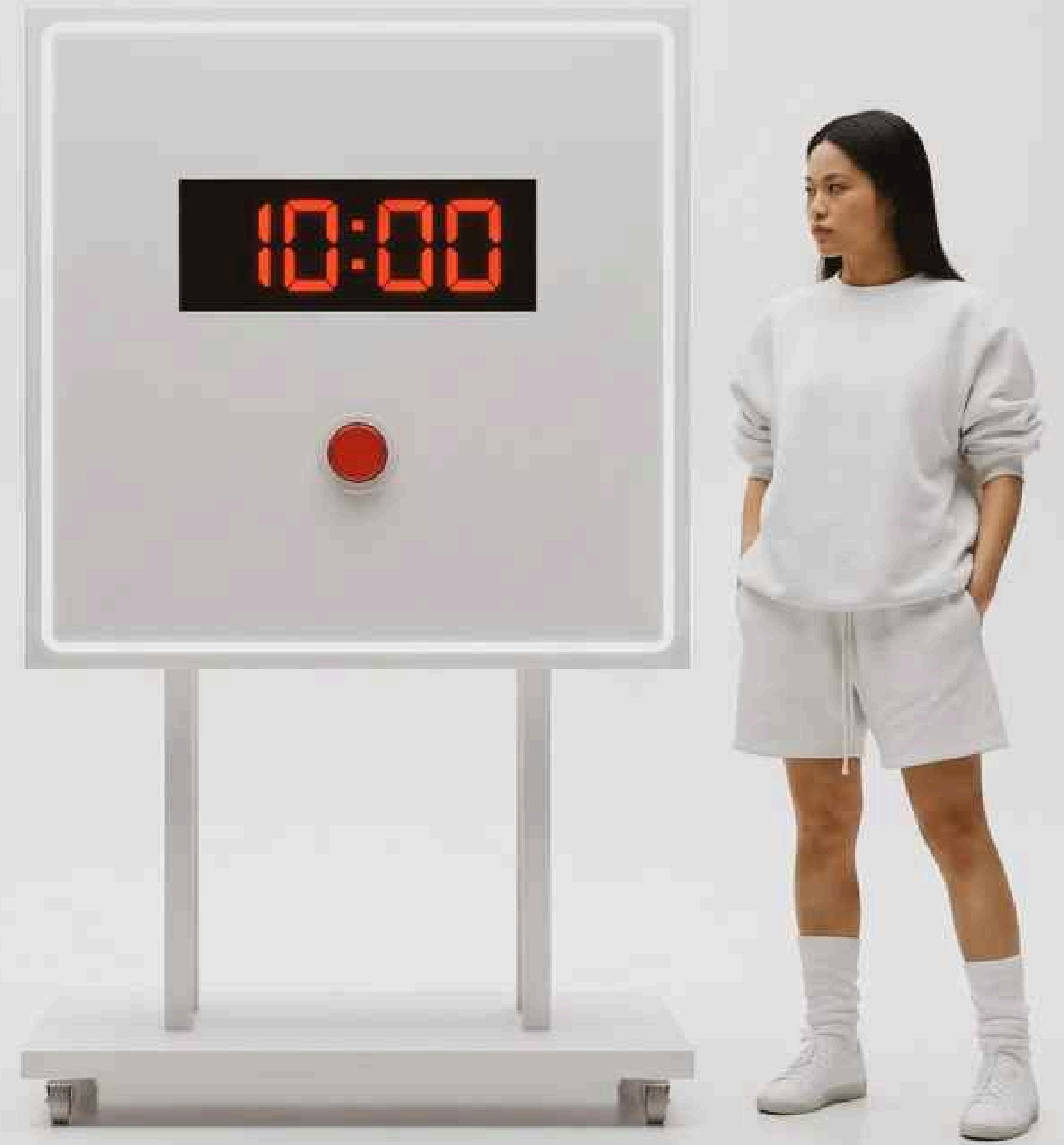

Plinko

A drop-and-win experience where a token bounces unpredictably through pegs into reward slots. Commonly used for prize distribution.

SKU ID	AR-001
Category	Analog Retro: Skill Challenge
Interaction duration	15-25 seconds
Daily interactions	400-500 participants per day
Lead time	7 working days (Qatar)
Base package	Custom-branded plinko set
Upgrades	Game usher with custom tshirt Data analytics integration



Maze Wheel

A hands-on skill challenge where players rotate a control wheel to navigate a ball through a physical maze, testing precision, coordination, and control.

SKU ID	AR-002
Category	Analog Retro: Skill Challenge
Interaction duration	50-60 seconds
Daily interactions	400-500 participants per day
Lead time	7 working days (Qatar)
Base package	Custom-branded maze with platform
Upgrades	Game usher with custom tshirt Data analytics integration





Overview

Where physical movement meets digital gameplay. Powered by motion tracking, sensors, and real-time feedback, these experiences turn the body into the controller, creating immersive, high-energy interactions that blur the line between physical and digital play.

Custom Branding Options
Finished with paint or vinyl wraps to match your brand identity and visual language.

On-Ground Facilitation
Trained staff manages gameplay, guide participants, and maintain flow.

Motion Sensor Powered
Powered by cameras, sensors, and connected hardware to track actions in real time.

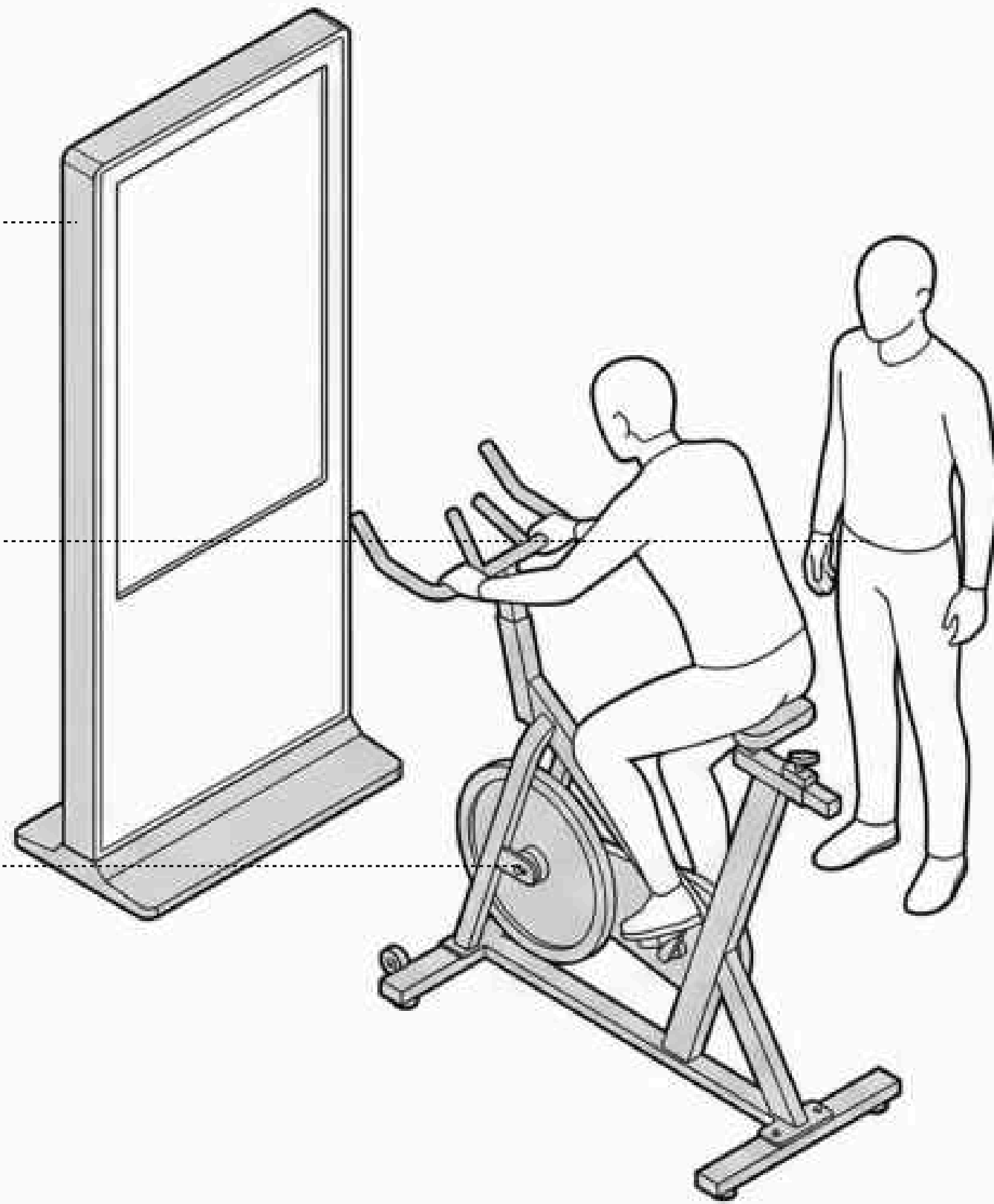

Modular Game Units
Pre-built systems designed to adapt seamlessly to different activation environments.

Body-Driven Interaction
Gameplay controlled through real-world movement, encouraging active participation.

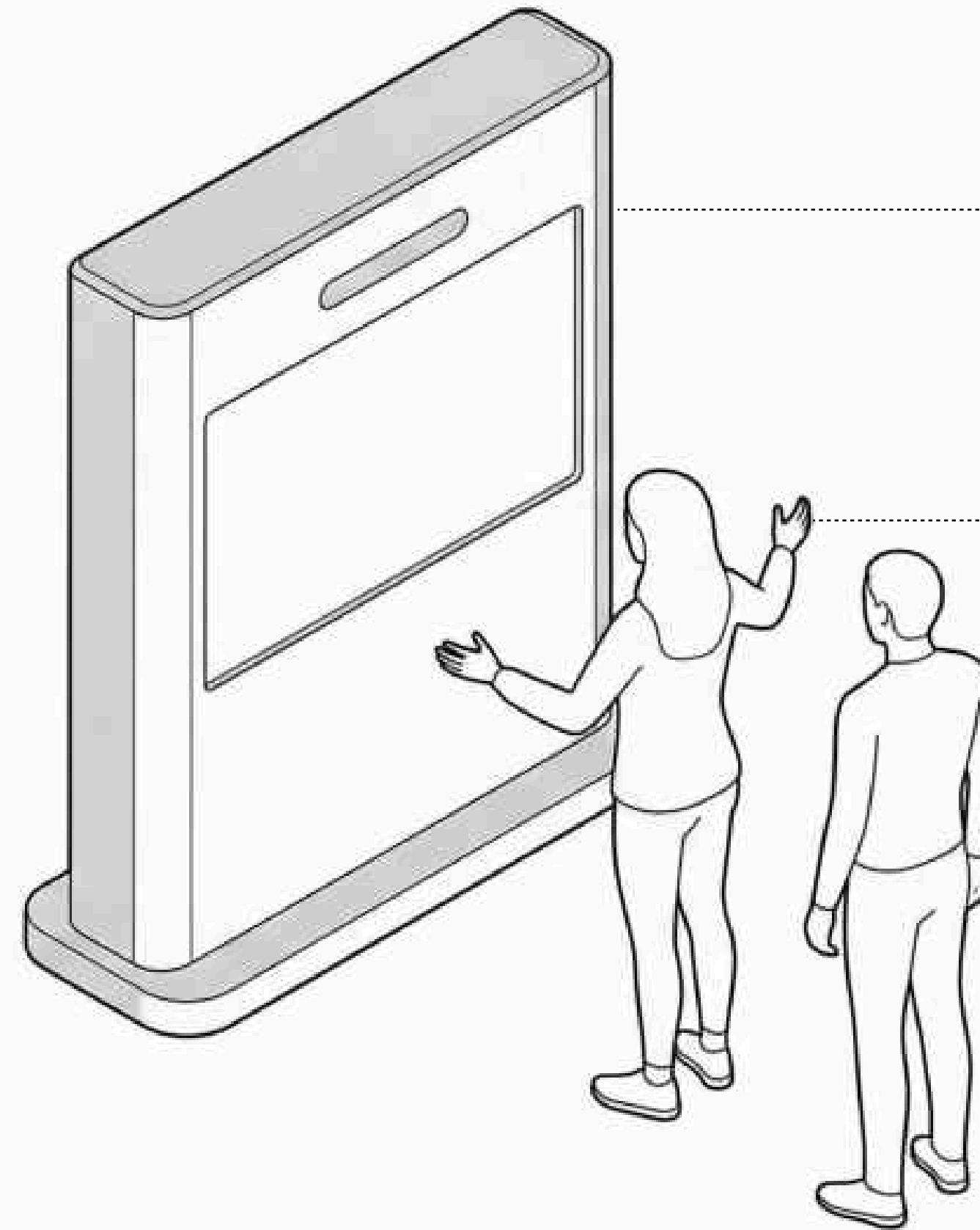

Tennis Smash

A fast-reaction motion-sensor based tennis game where players play against AI. Game is simplified for fast engagement.

SKU ID	PY-012
Category	Phygital Games: Skill Challenge
Interaction duration	50-60 seconds
Daily interactions	200-400 participants per day
Lead time	5 working days (Qatar)
Base package	55" touchscreen display Custom-branded game software Custom-branded screen casing Tennis Racket Booth facilitator with custom tshirt
Upgrades	Game mechanics modifications Data analytics integration



Tap Rush

Motion-tracking gameplay where players rapidly strike or tap virtual targets appearing on screen using body movement.

SKU ID	PY-001
Category	Phygital Games: Skill Challenge
Interaction duration	50-60 seconds
Daily interactions	200-400 participants per day
Lead time	5 working days (Qatar)
Base package	55" touchscreen display Custom-branded game software Custom-branded screen casing Booth facilitator with custom tshirt
Upgrades	Game mechanics modifications Data analytics integration



Goalkeeper

A fast-reaction penalty shootout game where players plays the goalkeeper in an attempt to catch balls kicked towards him/her.

SKU ID	PY-011
Category	Phygital Games: Skill Challenge
Interaction duration	50-60 seconds
Daily interactions	200-400 participants per day
Lead time	5 working days (Qatar)
Base package	55" touchscreen display Custom-branded game software Custom-branded screen casing Booth facilitator with custom tshirt
Upgrades	Game mechanics modifications Data analytics integration



Frame Dodge

Players dodge virtual laser frames entering the screen by moving their bodies left, right, or jumping away.

SKU ID	PY-005
Category	Phygital Games: Skill Challenge
Interaction duration	50-60 seconds
Daily interactions	200-400 participants per day
Lead time	5 working days (Qatar)
Base package	55" touchscreen display Custom-branded game software Custom-branded screen casing Booth facilitator with custom tshirt
Upgrades	Game mechanics modifications Data analytics integration

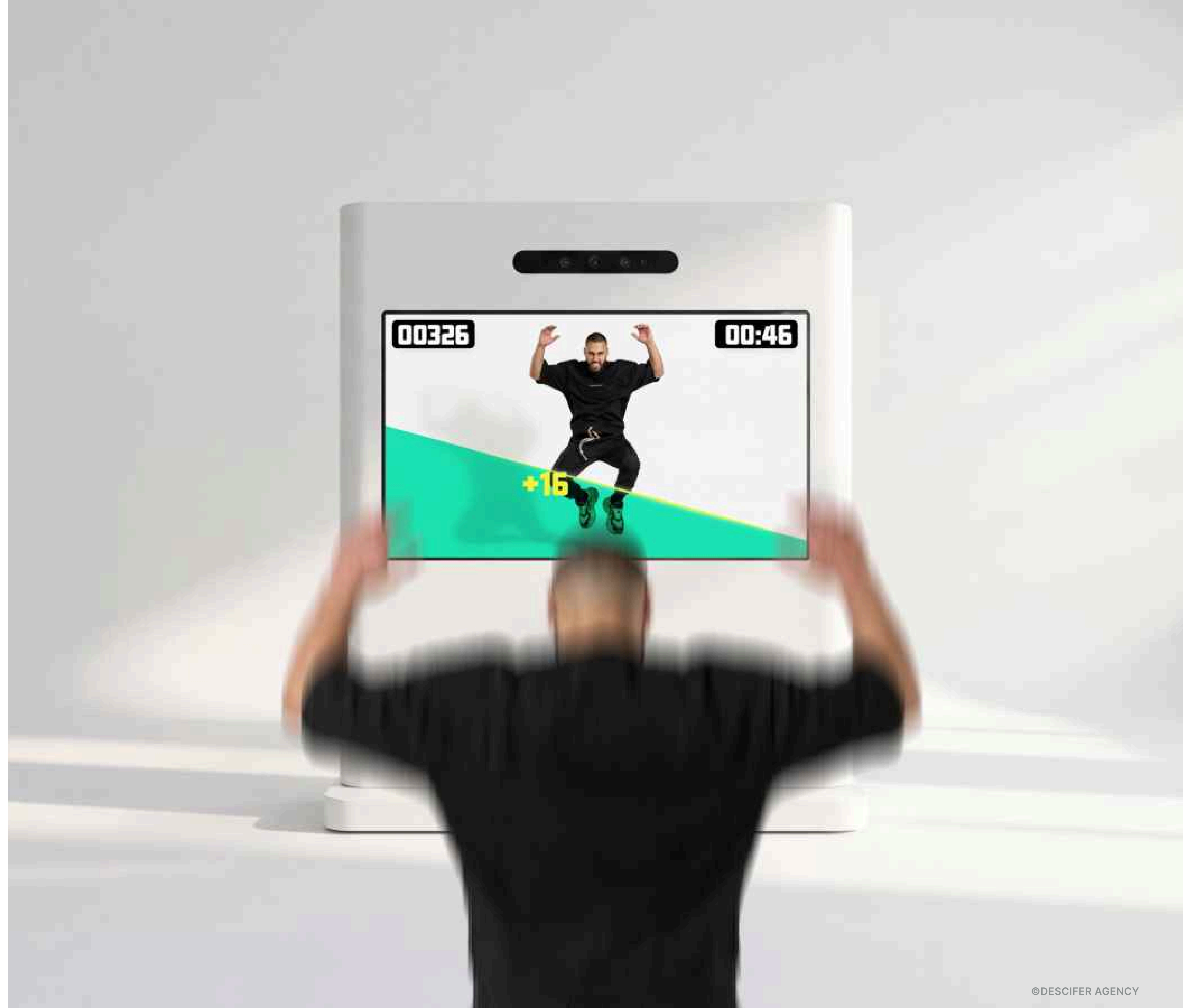

Fast Pass

Precision-based football gameplay where players stand inside a circular sensor ring and pass a ball toward illuminated targets, with real-time tracking to score accuracy and speed.

SKU ID	PY-008
Category	Phygital Games: Skill Challenge
Interaction duration	3-5 minutes
Daily interactions	80-120 participants per day
Lead time	12 working days (Qatar)
Base package	Sensor ring with target system Real-time scoring game software Custom-branded structure Custom-branded software Booth facilitator with custom tshirt
Upgrades	Game mechanics modifications Leaderboard system integration Data analytics integration



Whack-a-Mole

Fast-reaction gameplay where players strike emerging targets on screen using body movement, with motion tracking detecting hits and misses in real time.

SKU ID	PY-009
Category	Phygital Games: Skill Challenge
Interaction duration	50-60 seconds
Daily interactions	200-400 participants per day
Lead time	5 working days (Qatar)
Base package	55" touchscreen display Custom-branded game software Custom-branded screen casing Booth facilitator with custom tshirt
Upgrades	Game mechanics modifications Data analytics integration



Endless Runner

A motion-controlled quirky running game where players use body movement to navigate a character through obstacles, testing coordination, timing, and agility.

SKU ID	PY-010
Category	Phygital Games: Skill Challenge
Interaction duration	50-60 seconds
Daily interactions	200-400 participants per day
Lead time	12 working days (Qatar)
Base package	55" touchscreen display Custom-branded game software Custom-branded screen casing Booth facilitator with custom tshirt
Upgrades	Game mechanics modifications Data analytics integration



DIY Stations



Overview

A hands-on category focused on creation, personalization, and take-home experiences. These stations invite participants to design, assemble, or customize their own items, turning engagement into something tangible and memorable with strong personal value.

High Personalization Value
Participants create unique, customized items that reflect their style or the brand experience.

Turnkey Solution
Delivered as complete package with all required equipment, materials & knowhows



On-Ground Facilitation
Trained staff manages gameplay, guide participants, and maintain flow.

Tangible Takeaways
Designed around keepsakes that extend the brand interaction beyond the activation.

Modular Setup
Pre-built units that adapt seamlessly to different activation environments.

Lace Charm & Engraving

Guests customize lace charms or accessories using engraving or decorative elements to create personalized keepsakes.

SKU ID	DS-001
Category	DIY Station: Creative Personalization
Interaction duration	3-5 minutes
Daily interactions	80-120 participants per day
Lead time	9-10 working days (Qatar)
Base package	Custom-branded booth Charm materials & equipment Booth facilitator with custom tshirt
Upgrades	Custom-branded charms (+10 days) Data analytics integration



Jibbitz Style Keychain

Guests assemble and customize their keychain using jibbitz style charms.

SKU ID	DS-003
Category	DIY Station: Creative Personalization
Interaction duration	3-5 minutes
Daily interactions	80-120 participants per day
Lead time	9-10 working days (Qatar)
Base package	Custom-branded booth Charm materials & equipment Booth facilitator with custom tshirt
Upgrades	Custom-branded charms (+3 days) Custom-branded keychain (+3 days) Data analytics integration

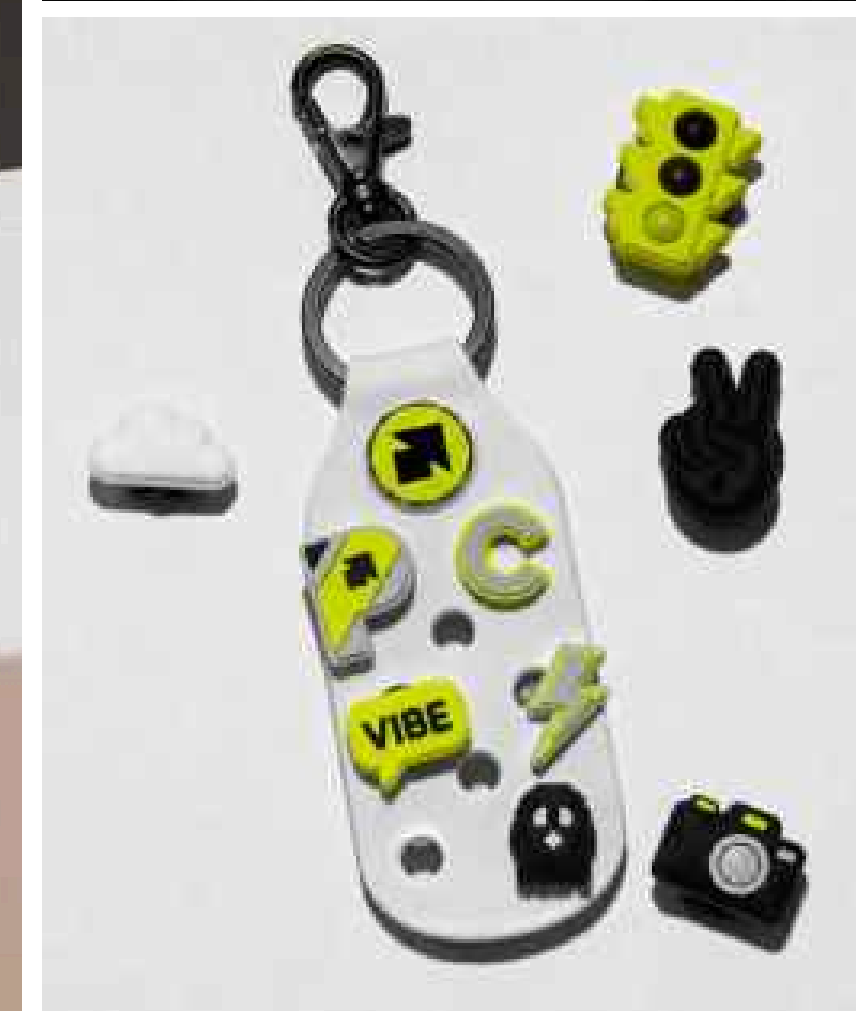

Clicker Keychain

Guests assemble and customize their keychain using letters of their choice.

SKU ID	DS-005
Category	DIY Station: Creative Personalization
Interaction duration	3-5 minutes
Daily interactions	80-120 participants per day
Lead time	9-10 working days (Qatar)
Base package	Custom-branded booth Charm materials & equipment Booth facilitator with custom tshirt
Upgrades	Custom-branded charms (+3 days) Data analytics integration



Bracelet Charm

Participants assemble or decorate bracelet charms using modular components and design elements.

SKU ID	DS-004
Category	DIY Station: Creative Personalization
Interaction duration	3-5 minutes
Daily interactions	80-120 participants per day
Lead time	9-10 working days (Qatar)
Base package	Custom-branded booth Charm materials & equipment Booth facilitator with custom tshirt
Upgrades	Custom-branded charms (+10 days) Data analytics integration



➤ Activation Utility



Overview

A suite of supporting tools and systems designed to enhance, manage, and amplify activation experiences. These utilities complement core interactions by enabling participation tracking, content capture, and real-time engagement, ensuring smoother operations and measurable outcomes.

Content Capture & Output
Photo, video, and AI-powered outputs designed for instant sharing or printing.

Custom Branding Options
Interfaces and physical setups can be aligned to your brand identity.

Turnkey Deployment
Delivered as complete systems with all required hardware and technology.

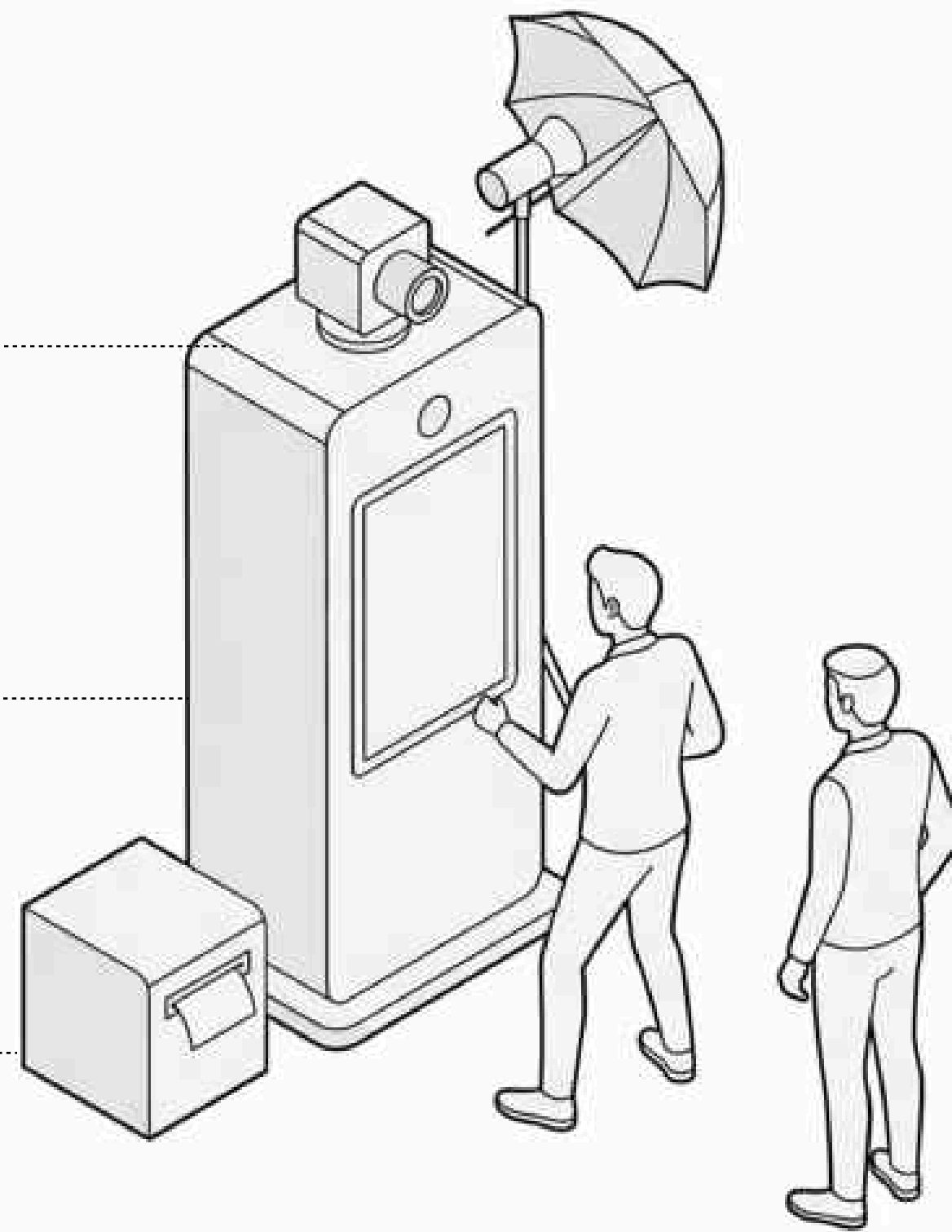

Participation Management
Systems for registration, check-ins, and structured user journeys.

Data & Engagement Tracking
Capture user data, monitor interactions, and measure performance in real time.

AI Photobooth

AI transforms participant photos into stylized or themed visuals instantly, delivered digitally or via print.

SKU ID	SU-001
Category	Utility: Creative Personalization
Interaction duration	2-3 minutes
Daily interactions	120-150 participants per day
Lead time	5-6 working days (Qatar)
Base package	Custom-branded AI photo booth Custom-branded software Booth facilitator with custom tshirt
Upgrades	Instant print station & materials Data analytics integration



Mirror Photobooth

A camera-based photo booth where participants see themselves in a mirrored screen interface before capturing photos that can be downloaded via QR or printed instantly.

SKU ID	SU-004
Category	Utility: Creative Personalization
Interaction duration	2-3 minutes
Daily interactions	120-150 participants per day
Lead time	5-6 working days (Qatar)
Base package	Custom-branded mirror photo booth Custom-branded software Booth facilitator with custom tshirt
Upgrades	Instant print station & materials Data analytics integration



Immersive Installations

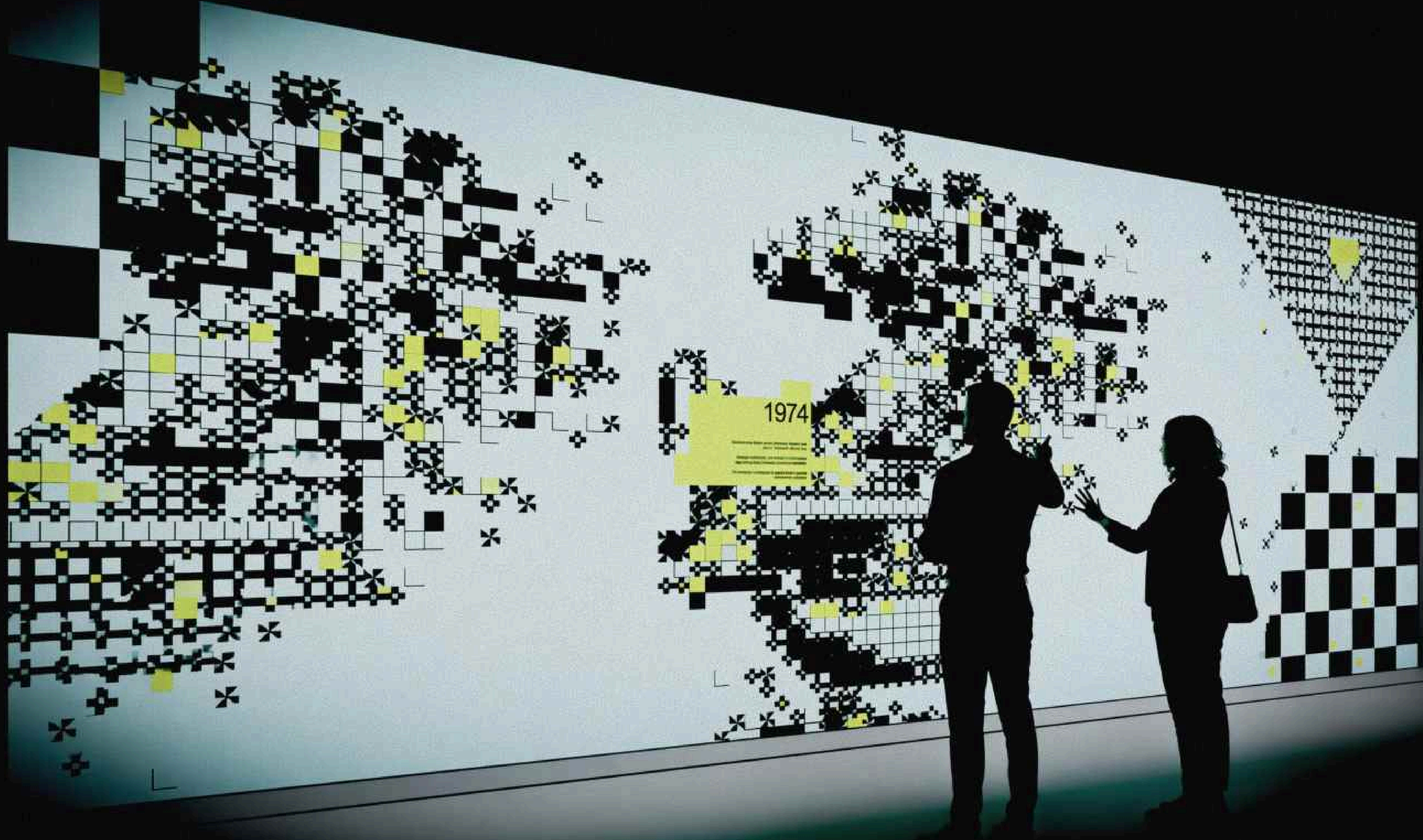

Overview

Technology-driven experiences designed to transform spaces into interactive digital environments. From AR to large-scale interactive walls, these installations combine advanced tech with intuitive interaction creating visually striking and highly engaging brand moments.

Highly Customizable Content
Flexible content design tailored to brand storytelling and campaign objectives.

Turnkey Deployment
Delivered as complete systems with all required hardware and technology.

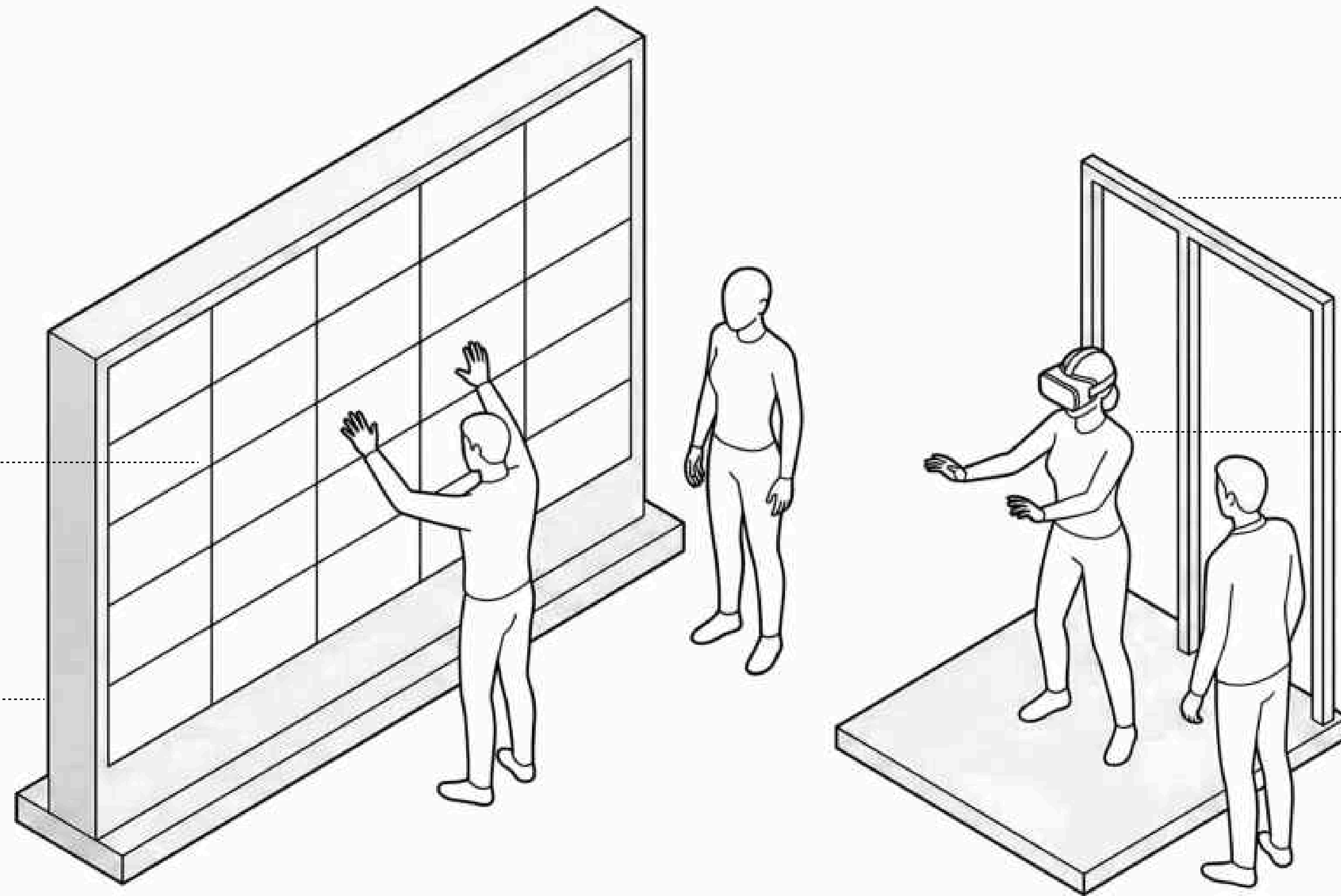

Immersive Environments
Transform walls and spaces into dynamic, interactive visual experiences.

Advanced Technology Stack
Powered by AR, projection systems, sensors, and real-time processing.



Brand Customization

Every interaction.
Customizable to your brand.

Brand Customization

Each interaction is sold with a pre-built templates that allows for efficient deployment while still offering meaningful brand integration.

Customization is applied across key touchpoints — ensuring your brand is clearly represented without compromising speed, reliability, or setup efficiency.

For fully bespoke builds, custom structures, or new gameplay development, dedicated solutions can be explored separately.

Pre-built structures.
Branded to your identity.



Standard systems.
Branded content.

Brand Customization



Physical Branding

All installations use pre-fabricated structures with defined formats allowing for fast deployment and consistency. Branding is applied through vinyl wraps, graphic applications, and paint finishes, transforming each unit to align with your visual identity.

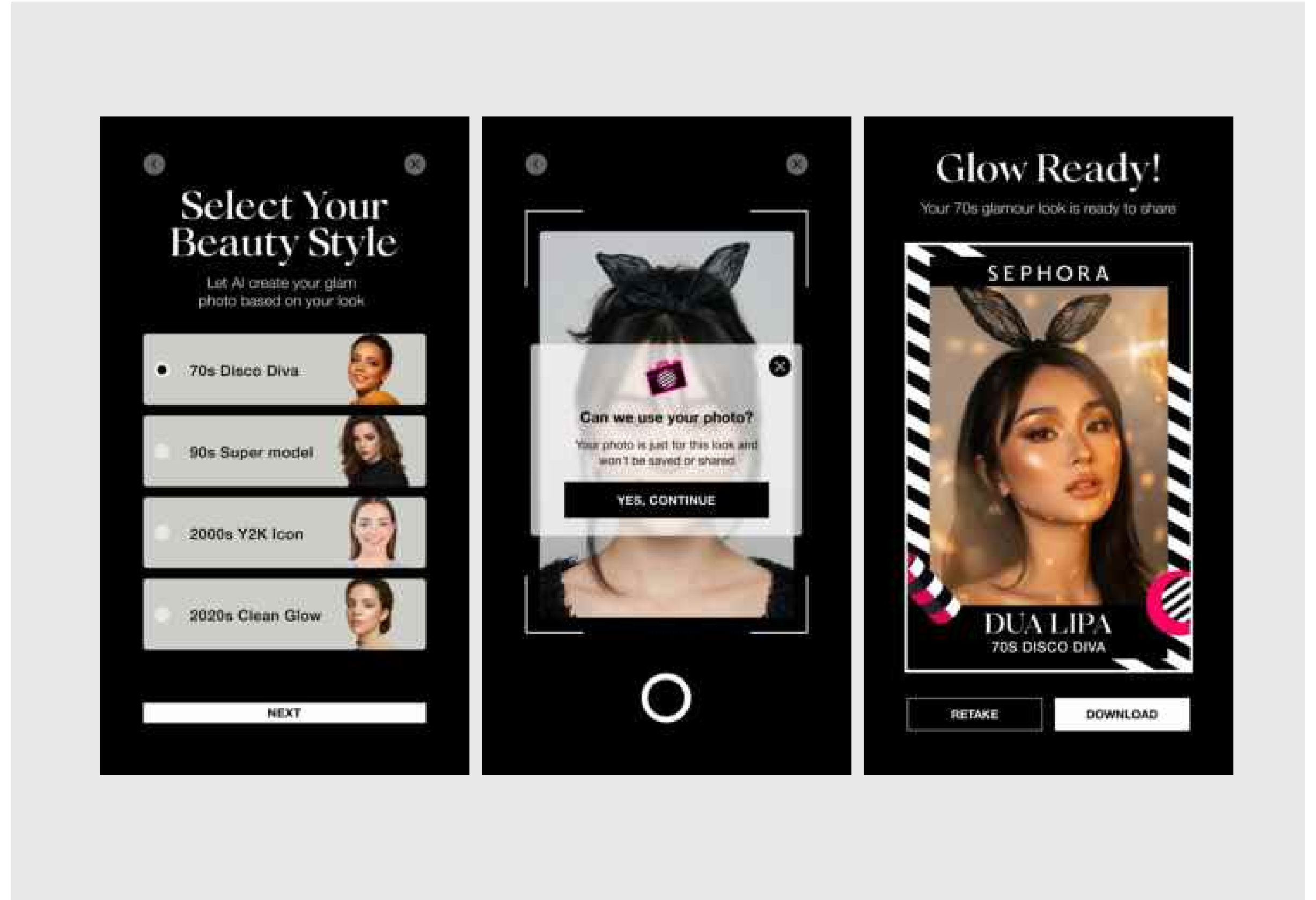

Digital & Content

Game interfaces, UI elements, and on-screen content can be fully adapted using your brand assets — including logos, colors, typography, and campaign visuals. While core mechanics remain consistent, the overall experience is tailored to reflect your brand and messaging.



About Us

A brand experience agency designing
interactive experiences at scale.



A performance-driven brand experience agency based in Qatar

Descifer is a design-led activation partner focused on creating interactive experiences that deliver measurable impact. Our approach combines modular systems, thoughtful design, and real-world execution, enabling brands to deploy high-impact activations that are not only engaging, but also efficient, scalable, and performance-driven.

Every solution is built with a clear focus on participation, user flow, and ROI, balancing creativity with

systems that are proven to perform in real environments.

Our work has been delivered across leading brands in Qatar, including Talabat, Keeta, QSTP, and PayLater — spanning mall activations, public events, and branded experiences. From concept to on-ground execution, our team manages the full lifecycle ensuring every activation is delivered with precision and measurable results.

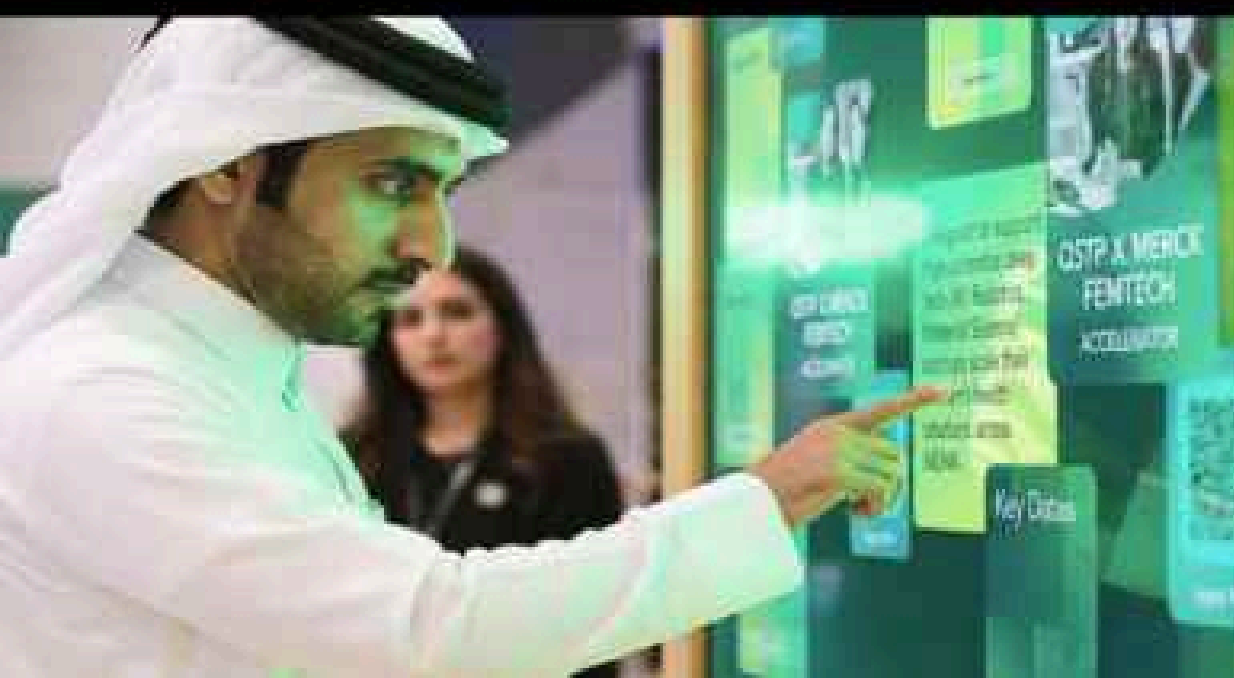

Select your interactions and get in touch with our team to begin. From customization to deployment, we'll guide you through every step.



Abbas Mechmech
Projects
abbes@descifer.com
+974 5502 1081



Ayham Berakdar
Business Development
ayham@descifer.com
+974 7757 7736



3, GROUND FLOOR
BURJ MARINA TOWER
MARINA DISTRICT
LUSAIL, DOHA

HELLO@DESCIFER.COM
+974 5049 8209